

AJ500/LG425R550SA

SOTR

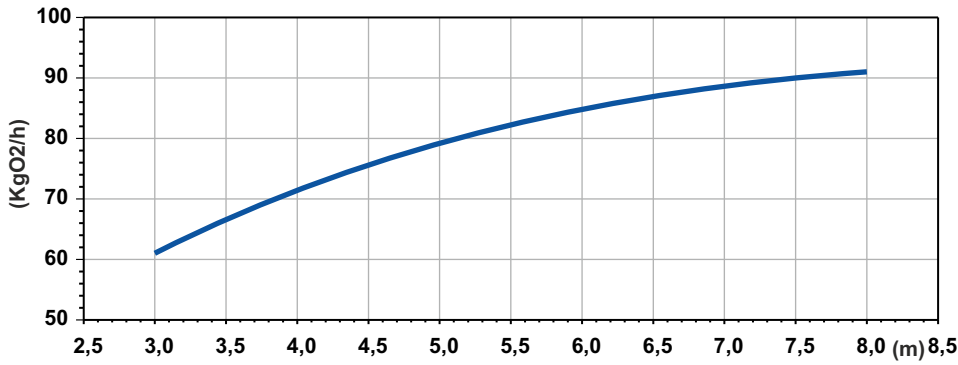

Potenza Assorbita - Absorbed Power P1
 Puissance Absorbée - Leistungsaufnahme P1
 Potencia Absorbida - Поглощенная мощность P1

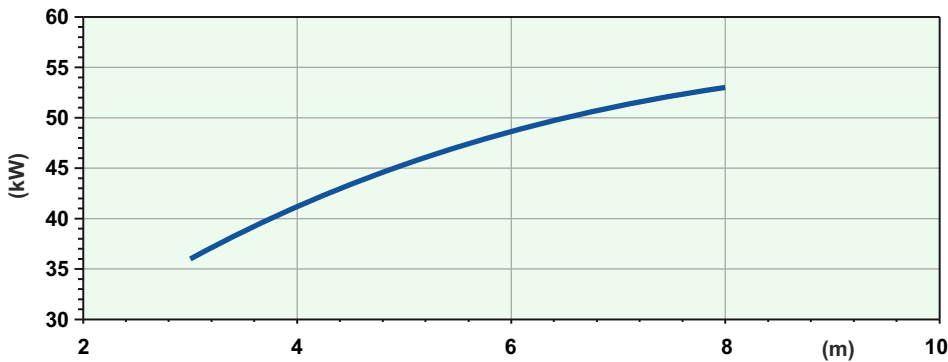

Battente idraulico - Hydraulic head - Charge hydraulique - Hydraulischen Belastung
 Cabezal hidráulico - Аспирированный воздух

Code	5009736
Type	AJ500/LG425R550SA
Suction (mm)	DN150
Free passage (mm)	40x50
Immersion depth (m)	3-8
Motor type	M425T-55,1-400/50YY-IE3
Power supply	3ph 400/690V-50Hz
MOTOR Rotation speed R.P.M.	1455
Rated power P2 (kW)	55,1
Rated current I (A)	93
Starting current Is (A)	549
Weight (Kg)	935
Cable	H07RN/F 2x4G25+4G2,5
SOTR OBTAINED FOLLOWING STANDARD UNI EN 12255-15:2004	

Dimensioni - Dimensions - Dimensions - Abmessungen - Dimensiones - Габариты (mm)

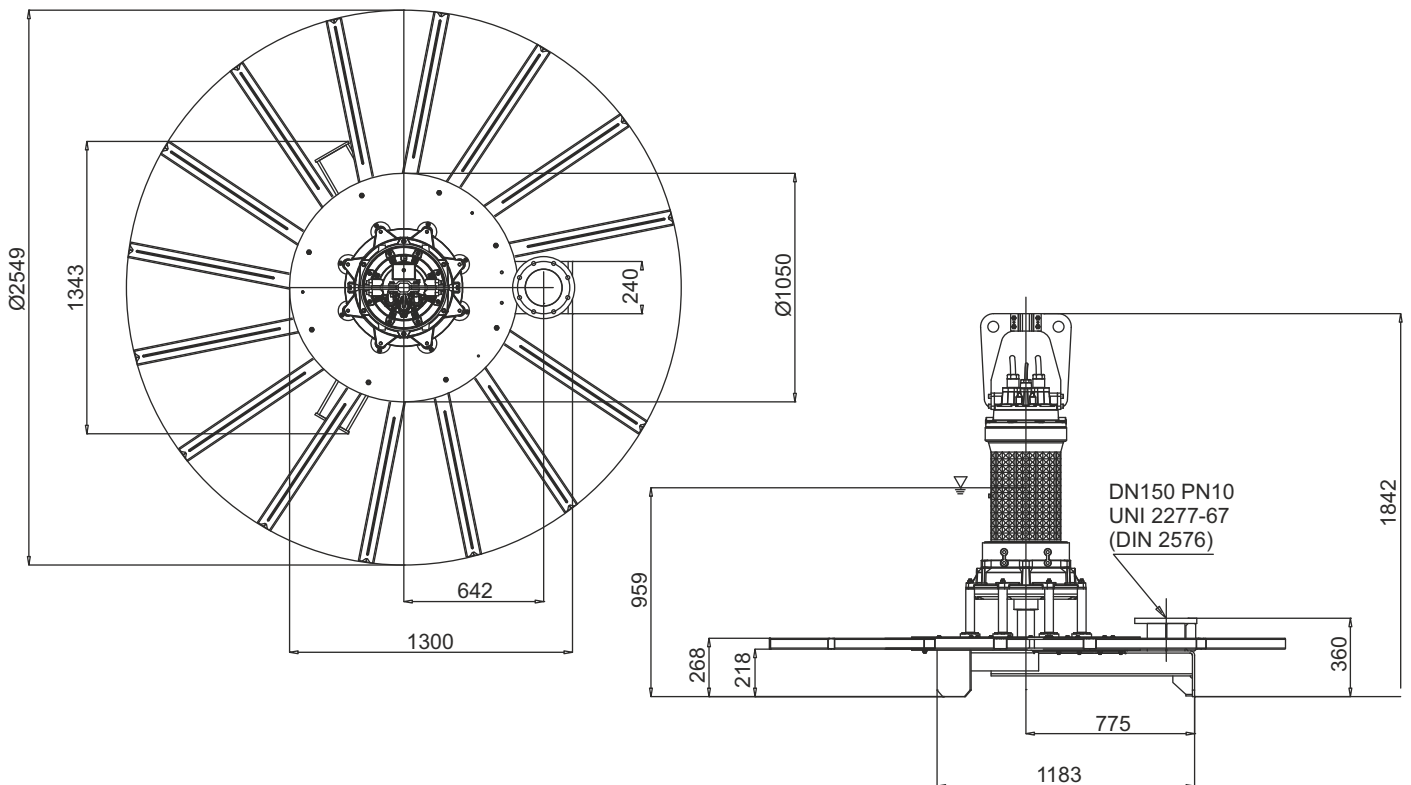

LIVELLO MINIMO DI SOMMERGIBILITÀ - MINIMUM SUBMERSIBLE LEVEL - NIVEAU MINIMUM D'IMMERSION
 MINDESTWASSERSTAND - NIVEL SUMERGIBLE MÍNIMO - МИНИМАЛЬНАЯ ГЛУБИНА ПОГРУЖЕНИЯ