

AJ30/LG410R40MA

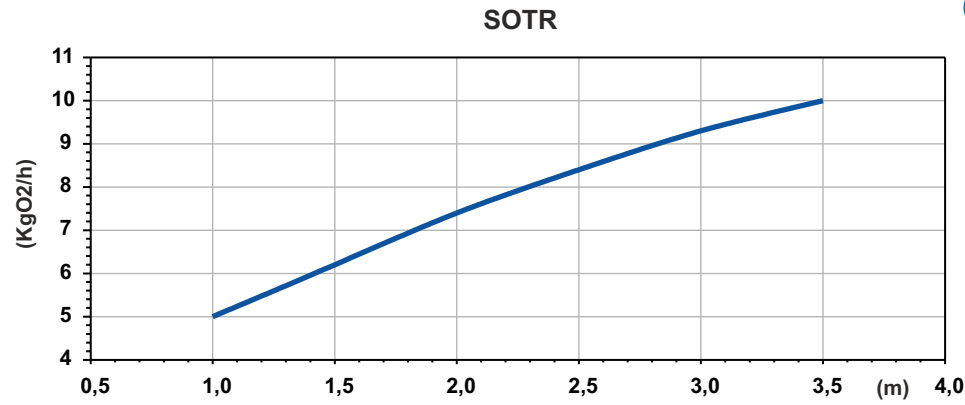

Potenza Assorbita - Absorbed Power P1
 Puissance Absorbée - Leistungsaufnahme P1
 Potencia Absorbida - Поглощенная мощность P1

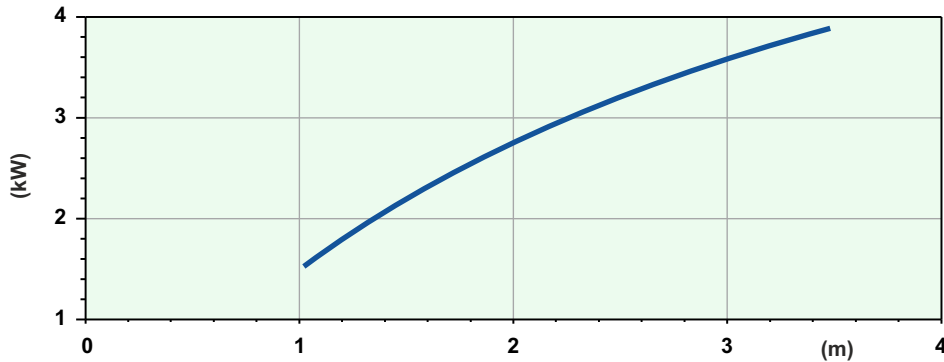

Battente idraulico - Hydraulic head - Charge hydraulique - Hydraulischen Belastung
 Cabezal hidráulico - Гидронапор

| | |
|--|------------------------|
| Code | 5006458 |
| Type | AJ30/LG410R40MA |
| Suction (mm) | DN80 |
| Free passage (mm) | 30x32 |
| Immersion depth (m) | 1-3,5 |
| Motor type | M410T-3,9-400/50YY-IE3 |
| Power supply | 3ph 400/690V-50Hz |
| MOTOR Rotation speed R.P.M. | 1401 |
| Rated power P2 (kW) | 3,9 |
| Rated current I (A) | 7,9 |
| Starting current Is (A) | 39,5 |
| Weight (Kg) | 152 |
| Cable | H07RN/F 12G1,5 |
| SOTR OBTAINED FOLLOWING STANDARD UNI EN 12255-15:2004 | |

Dimensioni - Dimensions - Dimensions - Abmessungen - Dimensiones - Габариты (mm)

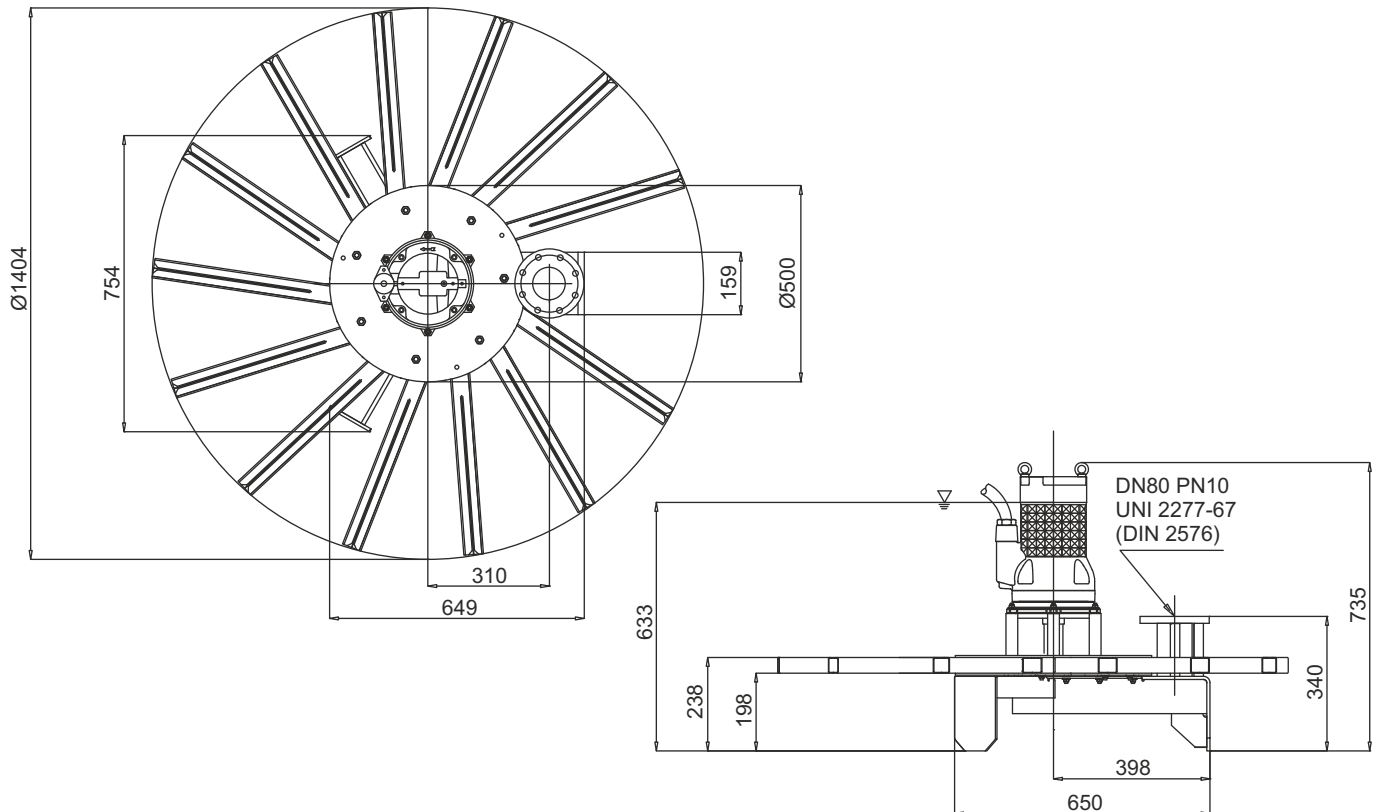

LIVELLO MINIMO DI SOMMERGIBILITÀ - MINIMUM SUBMERSIBLE LEVEL - NIVEAU MINIMUM D'IMMERSION
 MINDESTWASSERSTAND - NIVEL SUMERGIBLE MÍNIMO - МИНИМАЛЬНАЯ ГЛУБИНА ПОГРУЖЕНИЯ