





 Ghisa EN-GJL-250
 Fonte EN-GJL-250
 Hierro fundido EN-GJL-250

 Cast Iron EN-GJL-250
 Grauguss EN-GJL-250
 Чугун EN-GJL-250

Curva caratteristica - Performance curve - Courbe caractéristique
Kennlinie - Curva característica - Характеристическая кривая

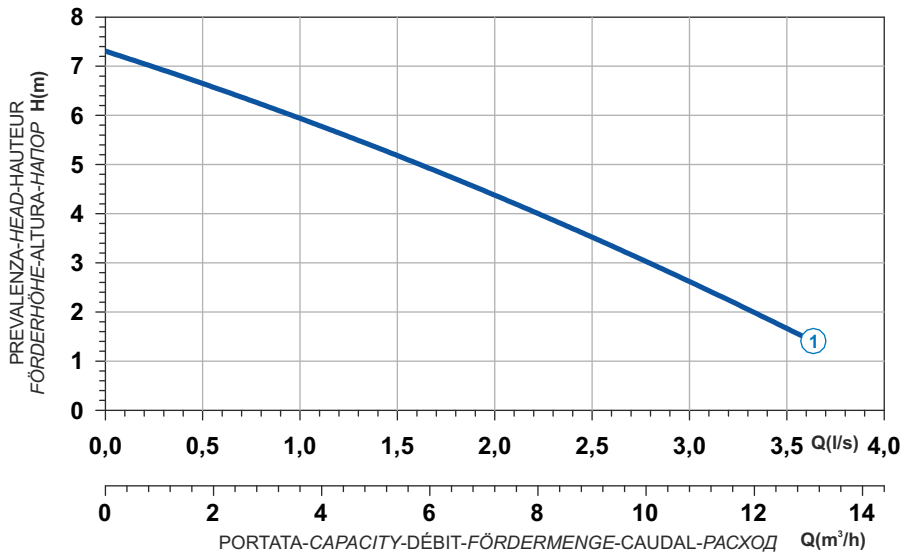

Curve N°	Code	Type	MOTOR			ATEX code 
			Rated power P2 (kW)	Rated current I (A)	Starting current Is (A)	
1	7002139	G206T6V1-D30AA0	0,6	1,2	5,4	-

Power supply	3ph 400V 50Hz
R.P.M.	2850
Free passage (mm)	30
Discharge (mm)	1"1/4
Max Weight (Kg)	13

Dimensioni - Dimensions - Dimensions - Abmessungen - Dimensiones - Габариты (mm)

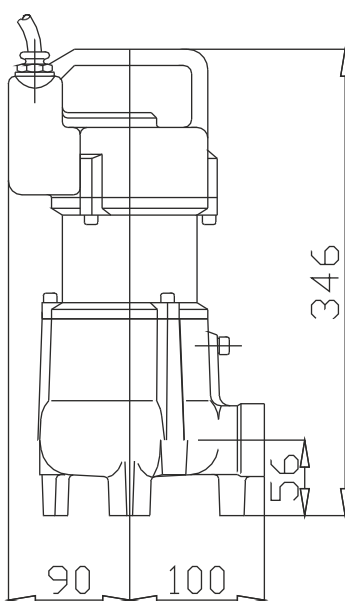

▽ LIVELLO MINIMO DI SOMMERSIBILITÀ
 MINIMUM SUBMERSIBLE LEVEL
 NIVEAU MINIMUM D'IMMERSION
 MINDESTWASSERSTAND
 NIVEL SUMERGIBLE MINIMO
 МИНИМАЛЬНАЯ ГЛУБИНА ПОГРУЖЕНИЯ

