



 Ghisa EN-GJL-250
 Fonte EN-GJL-250
 Hierro fundido EN-GJL-250

 Cast Iron EN-GJL-250
 Grauguss EN-GJL-250
 Чугун EN-GJL-250

Curva caratteristica - Performance curve - Courbe caractéristique
Kennlinie - Curva característica - Характеристическая кривая

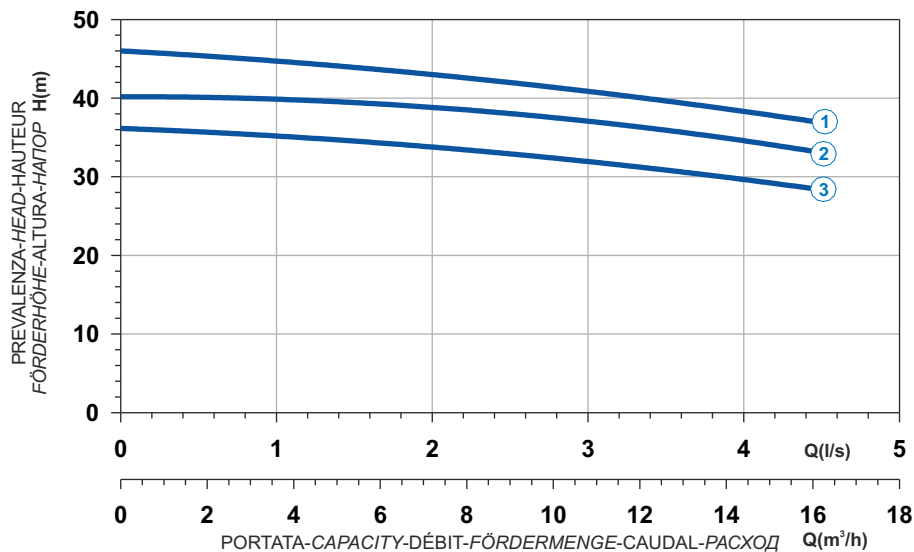

Curve N°	Code	Type	MOTOR			ATEX code 
			Rated power P2 (kW)	Rated current I (A)	Starting current Is (A)	
1	7001600	G210R6T1-J7AA2	5	9,1	53,7	7002801
2	7001923	G210R6T2-J7AA2	5	9,1	53,7	7002802
3	7001924	G210R6T3-J7AA2	4,2	7,7	45,4	7002803

Power supply	3ph 400/690V 50Hz
R.P.M.	2850
Free passage (mm)	7
Discharge (mm)	DN 40
Max Weight (Kg)	67

Dimensioni - Dimensions - Dimensions - Abmessungen - Dimensiones - Габариты (mm)

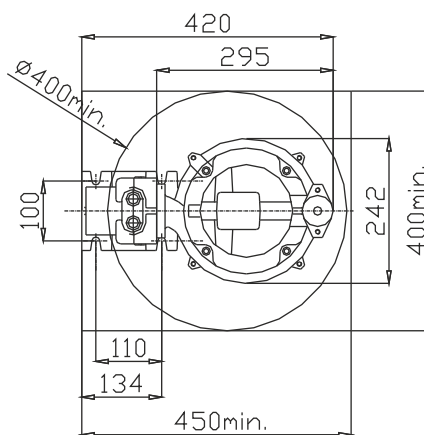
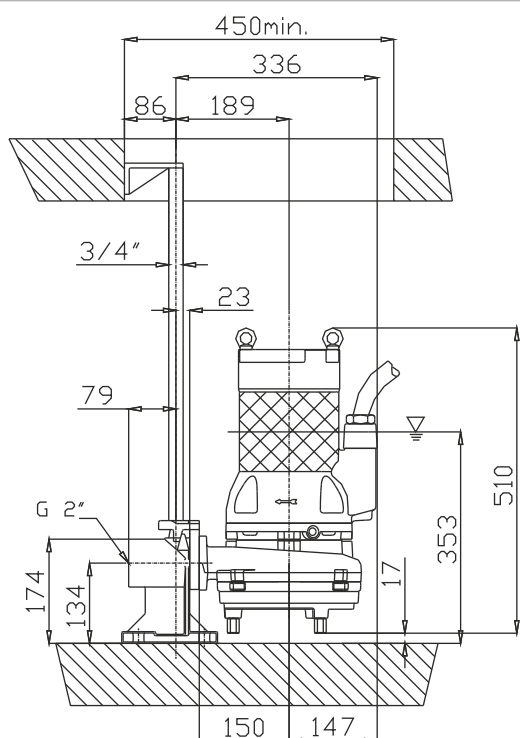

▽ LIVELLO MINIMO DI SOMMERGIBILITÀ
 MINIMUM SUBMERSIBLE LEVEL
 NIVEAU MINIMUM D'IMMERSION
 MINDESTWASSERSTAND
 NIVEL SUMERGIBLE MÍNIMO
 МИНИМАЛЬНАЯ ГЛУБИНА ПОГРУЖЕНИЯ

