

 Acciaio inox

 Acier inoxydable

 Acero inox

 Stainless steel

 Edelstahl

 Нержавеющая сталь

**Curva caratteristica - Performance curve - Courbe caractéristique
Kennlinie - Curva característica - Характеристическая кривая**

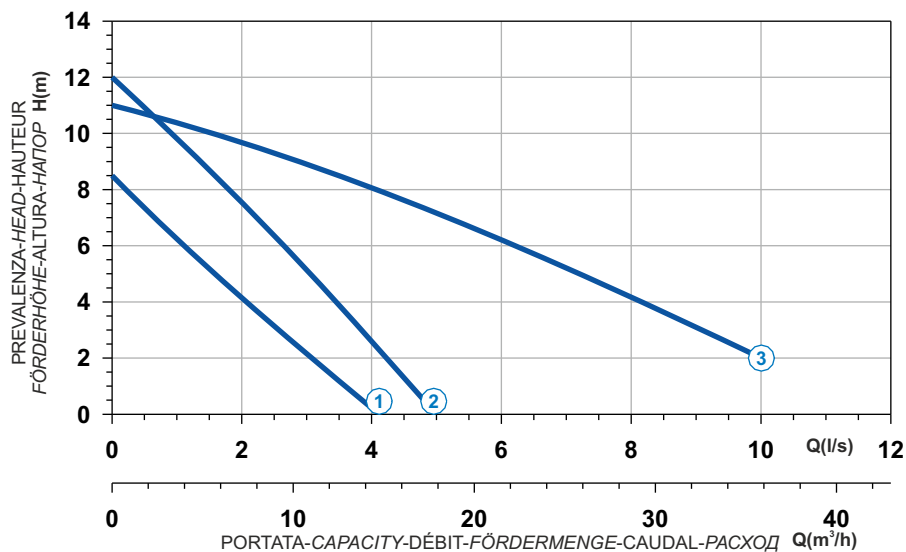

Curve N°	Code	Type	MOTOR				Free passage (mm)	Discharge	Weight (Kg)
			Power supply	R.P.M.	Rated power P2 (kW)	Rated current I (A)			
1	8002754	LVX-06T0-40	3ph 400V 50Hz	2850	0,58	1,1	35	1"1/2	7
2	8000876	LVX-09T0-40	3ph 400V 50Hz	2850	0,9	1,8	30	1"1/2	8,5
3	8001631	LVX-11T0-50	3ph 400V 50Hz	2850	1,1	3,2	50	2"	14

Dimensioni - Dimensions - Dimensions - Abmessungen - Dimensiones - Габариты (mm)

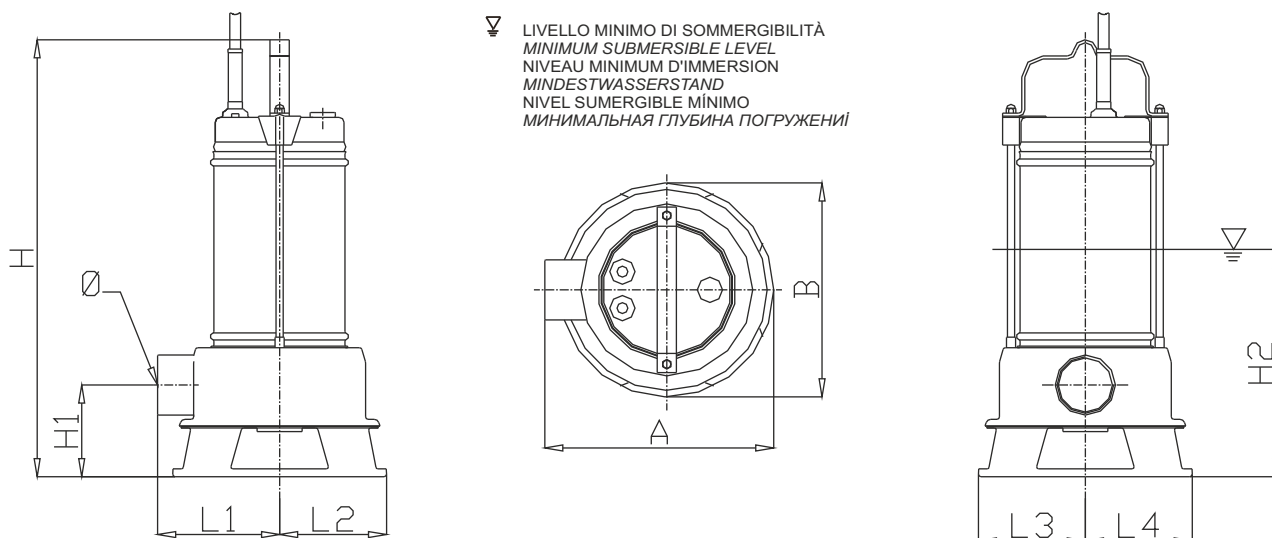

▽ LIVELLO MINIMO DI SOMMERSIBILITÀ
MINIMUM SUBMERSIBLE LEVEL
NIVEAU MINIMUM D'IMMERSION
MINDESTWASSERSTAND
NIVEL SUMERGIBLE MÍNIMO
МИНИМАЛЬНАЯ ГЛУБИНА ПОГРУЖЕНИЯ

Curve	Code	Type	H	H1	H2	A	B	Ø	L1	L2	L3	L4
1	8002754	LVX-06T0-40	365	76	195	195	180	1"1/2	105	95	95	95
2	8000876	LVX-09T0-40	405	76	215	195	180	1"1/2	105	95	95	95
3	8001631	LVX-11T0-50	480	107	265	230	220	2"	120	110	110	110